

--	--	--	--	--	--	--	--	--	--

Fifth Semester B.E. Degree Examination, Feb./Mar.2022
Design of Machine Elements – I

Time: 3 hrs.

Max. Marks:100

- Note:1. Answer any FIVE full questions, selecting at least TWO questions from each part.**
2. Use of Design data hand book permitted.
3. Any missing data can be suitably assumed.

PART – A

- 1 a. Sketch and explain biaxial and triaxial principal stress. (06 Marks)
b. Define standard and codes. (04 Marks)
c. A point in a machine member subject to plane stress as shown in Fig. Q1 (c). Determine the following :
(i) Normal and tangential stress intensities on plane MN inclined at an angle of 45°.
(ii) Principal stresses and their direction.
(iii) Maximum shear stress and direction of the planes on which it occurs. (10 Marks)

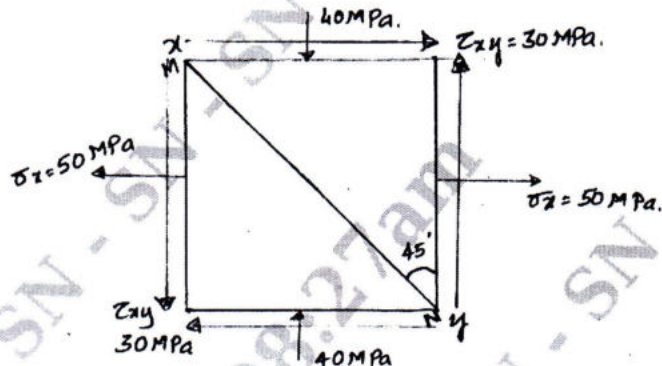

Fig. Q1 (c)

- 2 a. What is factor of safety and discuss factor influencing selection of appropriate value for factor of safety. (04 Marks)
b. Explain the Rankine's theory. (04 Marks)
c. A 60 mm diameter circular rod is subjected to loads as shown in Fig. Q2 (c). Determine the nature and magnitude of stress at critical point. (12 Marks)

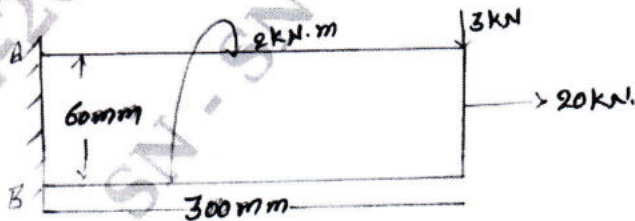

Fig. Q2 (c)

- 3 a. Explain the Soderberg's Criterion? (07 Marks)
b. Write the effect of factors on Endurance limit. (03 Marks)
c. A circular bar of 600 mm length is supported freely at its two ends. It is acted upon by a central concentrated cyclic load having a minimum value of 30 kN and a maximum value of 60 kN. Determine the diameter of bar by taking FOS of 2, size effect of 0.85, surface finish factor of 0.9. The material properties of bar are given by, ultimate strength 650 MPa, yield strength 500 MPa and endurance strength 350 MPa. (10 Marks)

Important Note : 1. On completing your answers, compulsorily draw diagonal cross lines on the remaining blank pages.
2. Any revealing of identification, appeal to evaluator and /or equations written eg. 42+8 = 50, will be treated as malpractice.

- 4 a. Define threaded fastness and explain the terminology of threaded screw. (08 Marks)
- b. A pulley bracket as shown in Fig. Q4 (b) is supported by 4 bolts, two at A-A and two at B-B. Determine the size of bolts using an allowable shear stress 30 N/mm^2 for the material of the bolts.

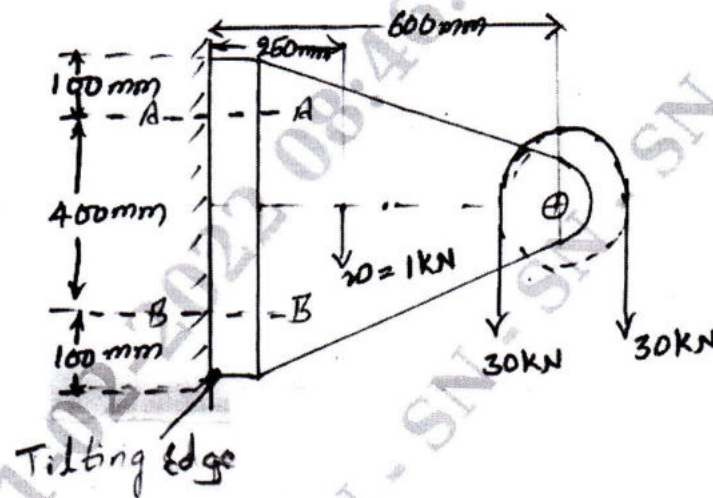

Fig. Q4 (b)

(12 Marks)

PART - B

- 5 a. Compare the weight, strength and stiffness of a hollow shaft with the same external diameter as that of a solid shaft. The inside diameter of the hollow shaft being half the external diameter. Both shaft have the same material and length. (08 Marks)
- b. A hoisting drum of 500 mm diameter is keyed on to a shaft and is intended for lifting a load of 20 kN at a velocity of 31.4 m/min. The shaft is supported on two bearings and carries a gear of 400 mm diameter overhanging the nearest bearing by 200 mm (i.e. 200 mm to the right of the right hand bearing). The gear ratio is 12 : 1. Determine the power and revolutions per minute of the motor required, assuming a drive efficiency of 90%. Determine also the diameter of the shaft for the hoisting drum, assuming that the material of the shaft has an allowable shear stress of 60 MPa. The distance between the bearings is 1000 mm. Pressure angle $\psi = 20^\circ$. For suddenly applied load with minor shocks the fatigue factor to be applied to the computed bending moment and the numerical combined shock and fatigue factor to be applied to the torsional moment are $C_m = 2$ and $C_t = 1.3$. Sketch the relevant bending moment diagrams. (12 Marks)
- 6 a. A splined connection in an automobile transmission consists of 10 splines, cut in 58 mm diameter shaft. The height of each spline is 5.5 mm and the key ways in the hub are 45 mm long. Determine the power that may be transmitted at 2500 rev/min. Allowable normal pressure on spline is limited to 5 MPa. (04 Marks)
- b. A rectangular sunk key 16 mm wide \times 12 mm thick \times 75 mm long is required to transmit 1400 N-m torque from a 50 mm diameter solid shaft. Determine whether the length is sufficient or not if the permissible shear stress and crushing stress are limited to 56 MPa and 168 MPa respectively. (06 Marks)
- c. Design a sleeve coupling to transmit 10 kW at 200 rpm. The allowable value of shear stress and compressive stress for the shaft and key material may be taken as 60 N/mm^2 and 130 N/mm^2 respectively. Use allowable shear stress in castiron sleeve equal to 15 N/mm^2 . (10 Marks)

- 7 a. A bracket in the form of a plate is fitted to a column by means of four rivets A, B, C and D in the same vertical line as shown in Fig. Q7 (a). $AB = BC = CD = 60$ mm and E is the mid point of B and C. A load of 50 kN is applied to the bracket at a point F, which at horizontal distance of 150 mm from E. The load acts at an angle 30° to the horizontal. Determine the diameter of rivets, which are made of steel having a yield stress in shear of 160 N/mm^2 . Take factor of safety of 2.

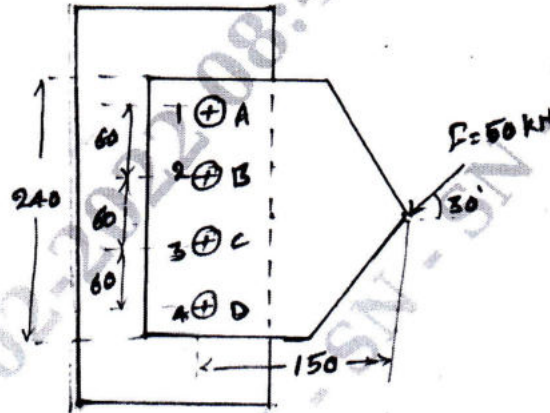

Fig. Q7 (a)

(10 Marks)

- b. A welded connection is as shown in Fig. Q7 (b). If the allowable stress is 100 N/mm^2 , determine the size of weld.

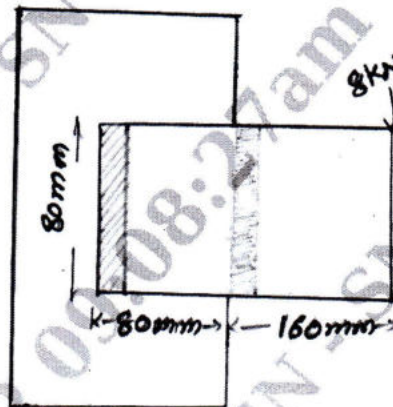

Fig. Q7 (b)

(10 Marks)

- 8 a. Explain self locking and overhauling in power screw. (04 Marks)
 b. What is thread and explain the types of threads? (06 Marks)
 c. A triple ISO, trapezoidal thread screw is operated by a torque of 40 N-m at its lower end. The nut is loaded and prevented from turning by guides. The screw has 48 mm outside diameter with 8 mm pitch. Assuming the thread co-efficient of friction is 0.15, determine
 (i) Whether the screw overhauls? Comment on it.
 (ii) The load which could be raised.
 (iii) The average bearing pressure between the screw and nut thread assuming nut length being 50 mm. (10 Marks)
